

VISTO PER APPROVAZIONE

DATA _____

	ANGOLO CADUTA TILT ANGLE	40,3°
VI	MARCHIO DI FABBRICA TRADE MARK	
A	CONTRASSEGNO TIPO VETRO GLASS TYPE	
00	NUMERO STAMPO CAVITY NUMBER	
2	ZIGRINATURA KNURLING	
3	PUNTI LETTORE CAVITA' DOTE CODE	
4	CODICE ALFANUMERICO NUMERIC CODE	
5	GODRONATURA A DISCREZIONE DELLA VETRERIA STIPPLING AT THE DISCRETION OF THE GLASS MAKER	
©	CONTROLLO STATISTICO STATISTICAL CONTROL	

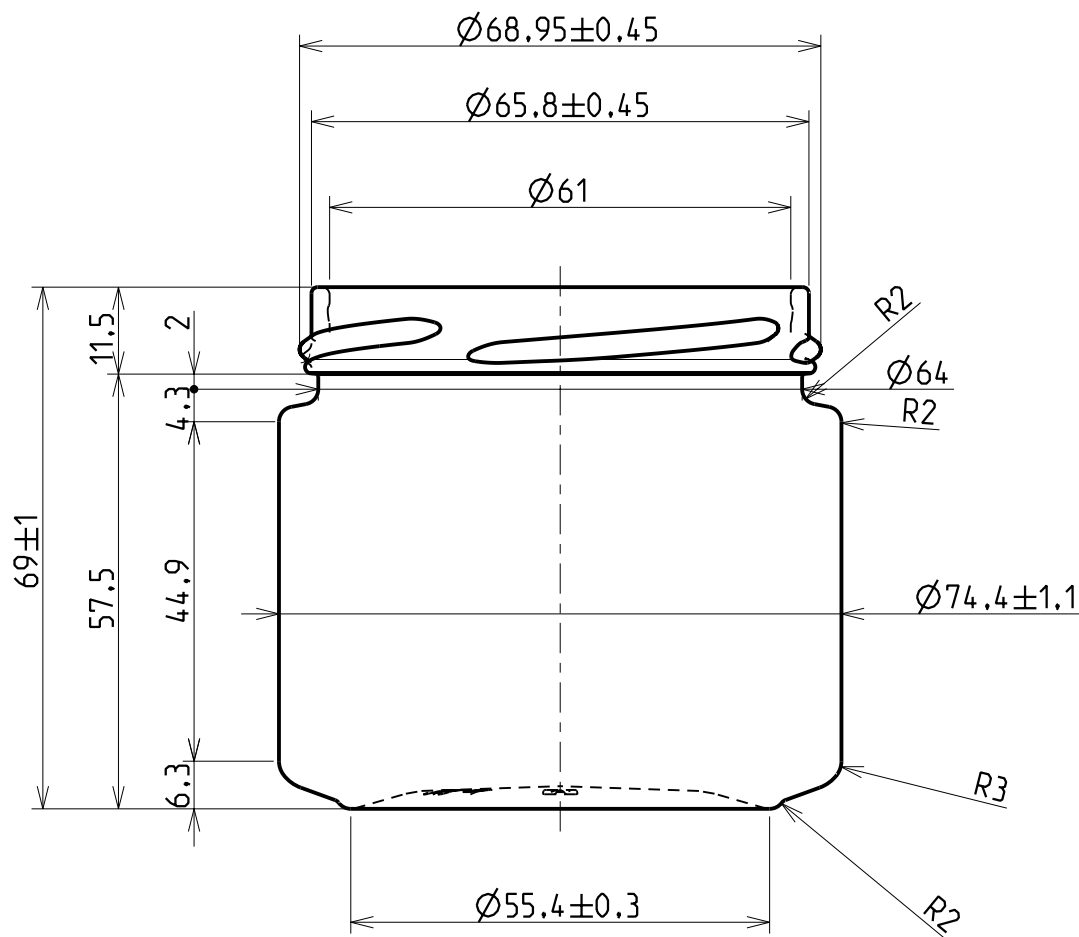
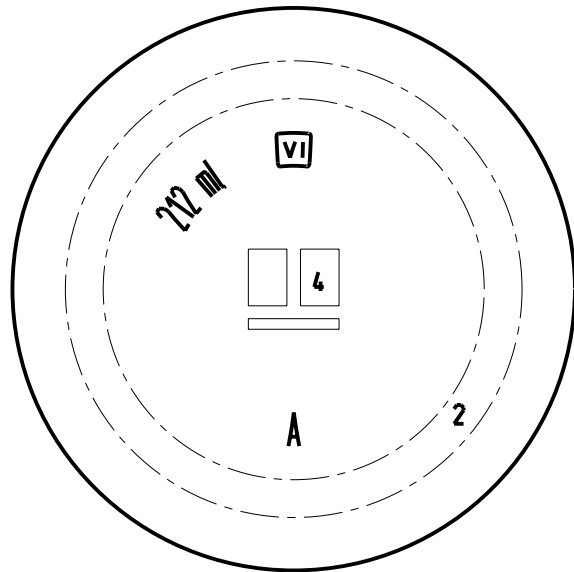

R.V.	DATA	NC	DESCRIZIONE MODIFICA - MODIFICATION DESCRIPTION	FORMAT
				A3



ARTICOLO ARTICLE	VASO PLATINUM 21,2-T70	PROGETTISTA DRAWING BY	M. Mazza	CAPAC. RB (cl) BRIMFULL CAPACITY	21,2 ± 0,6	©
BOCCA FINISH	TWIST OFF 70 REGULAR FD 138-S	DATA DATE	27/09/12	PESO (gr) GLASS WEIGHT	155	
CLIENTE CUSTOMER	VARI	APPROVATO DA APPROVATED BY	R. Pedrazzi	COD. BOCCA FINISH CODE	B000577_001	
DIAMETRO MIN. FORO PASSANTE MINIMUM INTERNAL DIAMETER	54	TOLLERANZA VERTICALITA' VERTICALITY TOLERANCE	± 1	SCALA SCALE	1:1	STUDIO CODE STUDY
					ST16808	R.V. A.0

QUESTO DISEGNO E' DI PROPRIETA' DI SAINT-GOBAIN VETRI SPA / This design is property of SAINT-GOBAIN VETRI SPA - NE E' VIETATA LA RIPRODUZIONE SENZA PREVENTIVA AUTORIZZAZIONE SCRITTA / Any reproduction without previous written permission is prohibited

QUOTE ESPRESSE IN mm / Dimension expressed in mm - SOLO LE QUOTE CON INDICAZIONE DI TOLLERANZA SONO IMPEGNATIVE / Dimensions are contractual only when tolerances are indicated.